

PARTS LIST			
ITEM	QTY	DESCRIPTION	MATERIAL/REF.
1	1	5/16" SUPERSEAL x 1/4 BSP STR ADAP BODY COMP.	ACETAL-HOECHST HOSTAFORM C9021 & M90/07/K20/95500
2	1	5/16" SUPERSEAL SCREWCAP	ACETAL-HOECHST HOSTAFORM C9021 & M90/07/K20/95500
3	1	THREADED END PIECE 5/16" SUP' SEAL x 1/4 BSP STR ADAP	ACETAL-HOECHST HOSTAFORM C9021 & M90/07/K20/95500
4	1	5/16" (8mm) COLLET	ACETAL-HOECHST KEMATAL M90/14/010 & M90/07/K20/95400
5	1	5/16" (8mm) STRIP FORM	301 S21 STAINLESS STEEL
6	2	5/16" (8mm) 'O' RING (GREASED)	NITRILE- SUPERIOR SEALS MATL' REF WN70/2
7	1	5/16" COMPRESSION RING	ACETAL-HOECHST HOSTAFORM C9021 & M90/07/K20/95500
8	1	1/4 BSP THREAD SEAL	NITRILE- SUPERIOR SEALS MATL' REF WN70/2

ISSUE	DATE	BY	ECN	CHK'D	APP'D
1	08-07-96	J.G.T.		AH	
5	C-3622-SALE				AH

THIS DRAWING COMPLIES WITH

MATERIAL SCALE 4:1  
DRN BY J.G.T.

COLOUR/FINISH DATE DRN 04-07-96

GENERAL LIMITS UNLESS OTHERWISE STATED  
 DIMENSIONS 0.00 ± 0.10  
 0.0 ± 0.15  
 ±  
 RADII ± 0.15  
 ANGLES ± 2°  
 SURFACE FINISH 1.6 MICRONS

DIMENSIONS ON THIS DRAWING ARE mm UNLESS OTHERWISE STATED

THE COPYRIGHT IN THIS DRAWING AND THE PRODUCTS REFERRED THEREON BELONG TO JOHN GUEST LIMITED AND THIS DRAWING NOR THE INFORMATION CONTAINED HEREIN SHALL BE PRODUCED IN ANY FORM OR USED FOR ANY PURPOSE WITHOUT WRITTEN CONSENT © 1996

John Guest Engineering  
**CURRENT PRODUCTION**  
Engineering server file and authorised CDROMs are controlled copies, all other copies and printouts are uncontrolled © John Guest

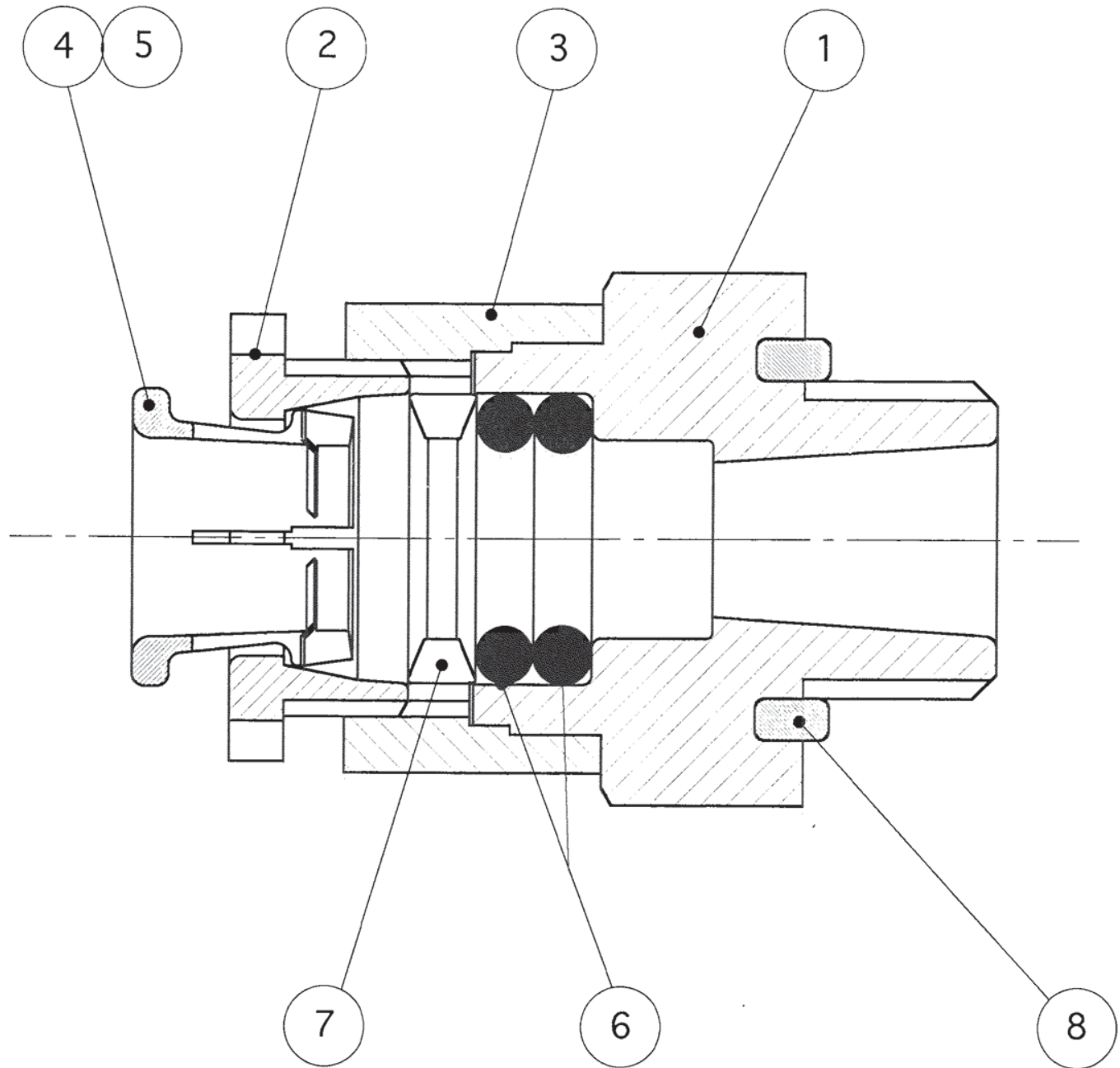

**JG** JOHN GUEST LTD  
 WEST DRAYTON  
 MIDDLESEX ENGLAND

TITLE  
**5/16" x 1/4 BSP STRAIGHT ADAPTOR**

DRAWING NO.  
**GA-SM010812S**

ISSUE 1  
 SHT 1 OF 1 SHTS

JGE FORM 103/A3/CC 18/06 1

000003-C-CIFM MCL1