

Product Data Sheet

10mm Brass Barb Connector

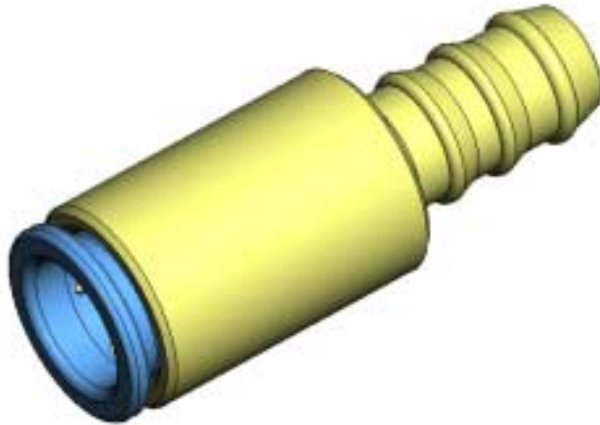

John Guest



Applications	
Top Heating	✓

Working Pressures and Temperatures

10 Bar at +1 °C 10 Bar at +23 °C 7 Bar at +70 °C

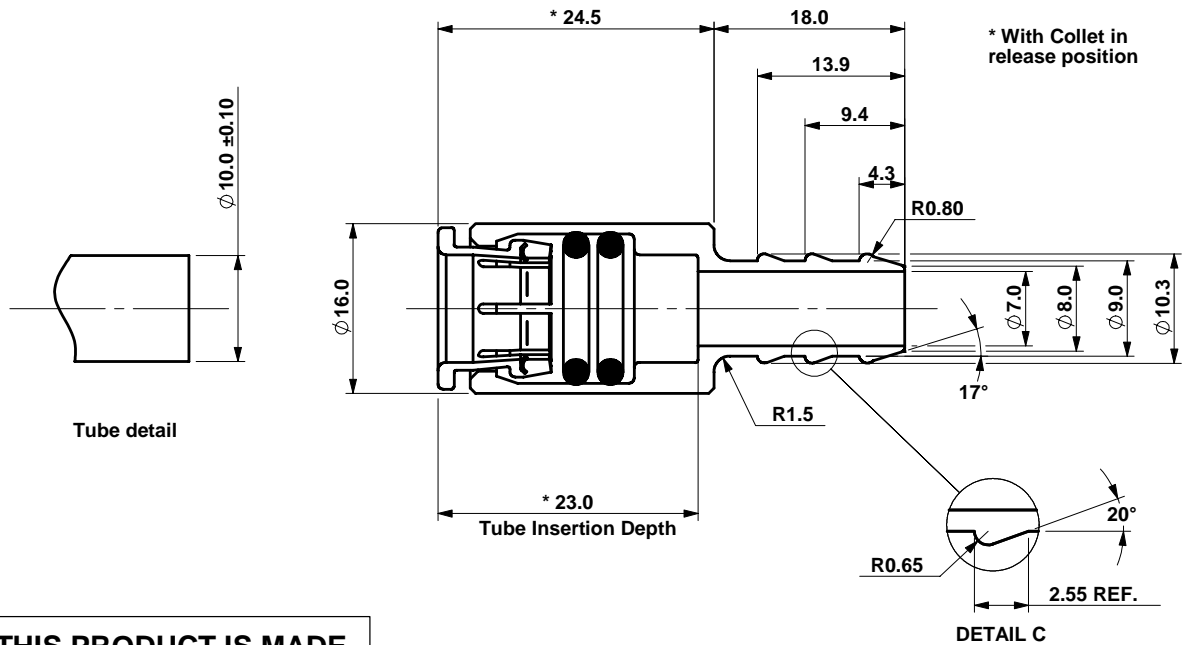

THIS PRODUCT IS MADE FROM NON-DZR BRASS

Product Description	Material
Body	Brass, CZ121 (Bright Nickel Plate).
Collet	Acetal Co-polymer (Unfilled) Black / Stainless Steel.
'O' Rings	Ethylene Propylene (EDPM), Black.

All Dimensions in mm

ECN13482

THE COPYRIGHT IN THIS DRAWING AND THE PRODUCTS REFERRED THEREON BELONG TO JOHN GUEST INTERNATIONAL LIMITED AND THIS DRAWING NOR THE INFORMATION CONTAINED HEREIN SHALL BE PRODUCED IN ANY FORM OR USED FOR ANY PURPOSE WITHOUT WRITTEN CONSENT © 2003

The company has a policy of continuous research and development and reserves the right to amend without notice the specification and design of all products illustrated. For details of terms and conditions and any other technical enquiries, please contact our Customer Services Department.

ISSUE 2

25-02-03

DS-NC863-02

ECN13482
REDRAWN IN SOLIDWORKS

ISSUE	DATE DRAWN	DATE ISS.	DRN. BY	ISS. BY	ECN	CHECKED	APPROVED
1	25-02-03	25-02-03	TB	TB	13482	DAP	DAP

DATA SHEET No.	DS-NC863-02
TITLE	10mm BRASS BARB CONNECTOR