

12mm - 3/8" Reducing Bulkhead Connector

The John Guest 12mm - 3/8" Reducing Bulkhead Connector is suitable for a wide range of applications including potable liquids and drink dispense.

*With Collet(s) in release position

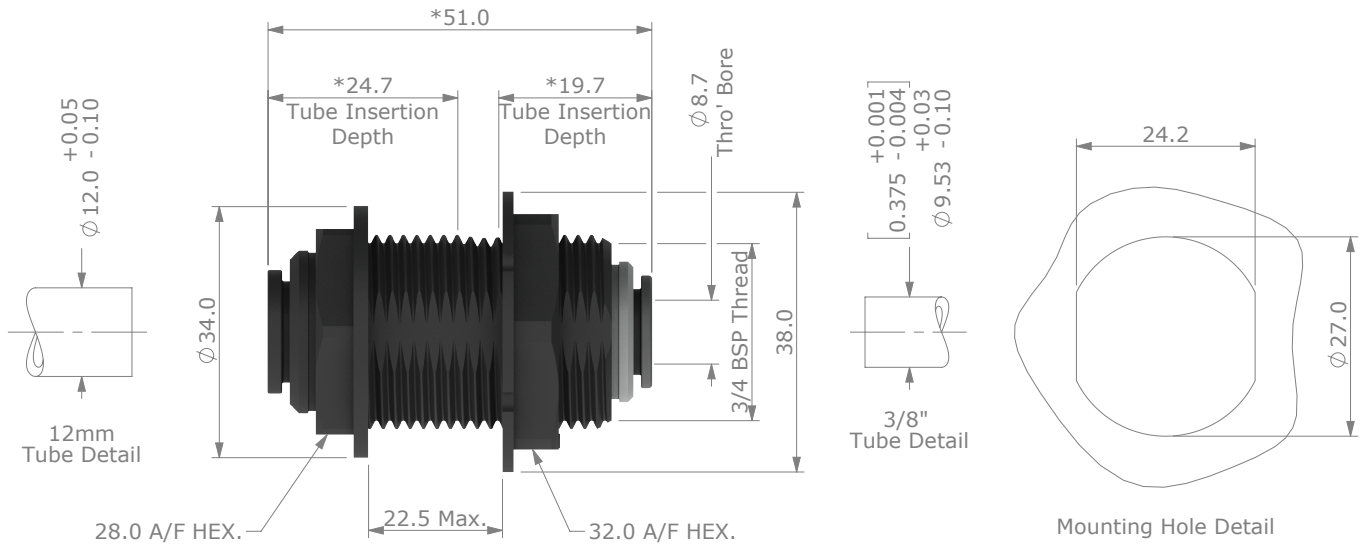

Dimensions in mm

Parts List

Part Description	Material	Part Description	Material
Body	Acetal Copolymer (Unfilled), Black / Light Grey	'O'Ring	Ethylene Propylene (EPDM), Black
Collets	Acetal Copolymer (Unfilled), Black / Dark Grey & Stainless Steel	Locknut	Acetal Copolymer (Unfilled), Black

Technical Information
Working Pressures & Temperatures

Potable Liquids 10bar at 1 °C 10bar at 20 °C 7bar at 65 °C

Maximum Torque: 4.0 Nm

Applications

Drinks Dispense

Potable Liquid