

**15mm x 1/2 BSP Flexi Hose (1000mm)**

The 15mm x 1/2 BSP Flexi Hose is designed for Domestic plumbing applications.

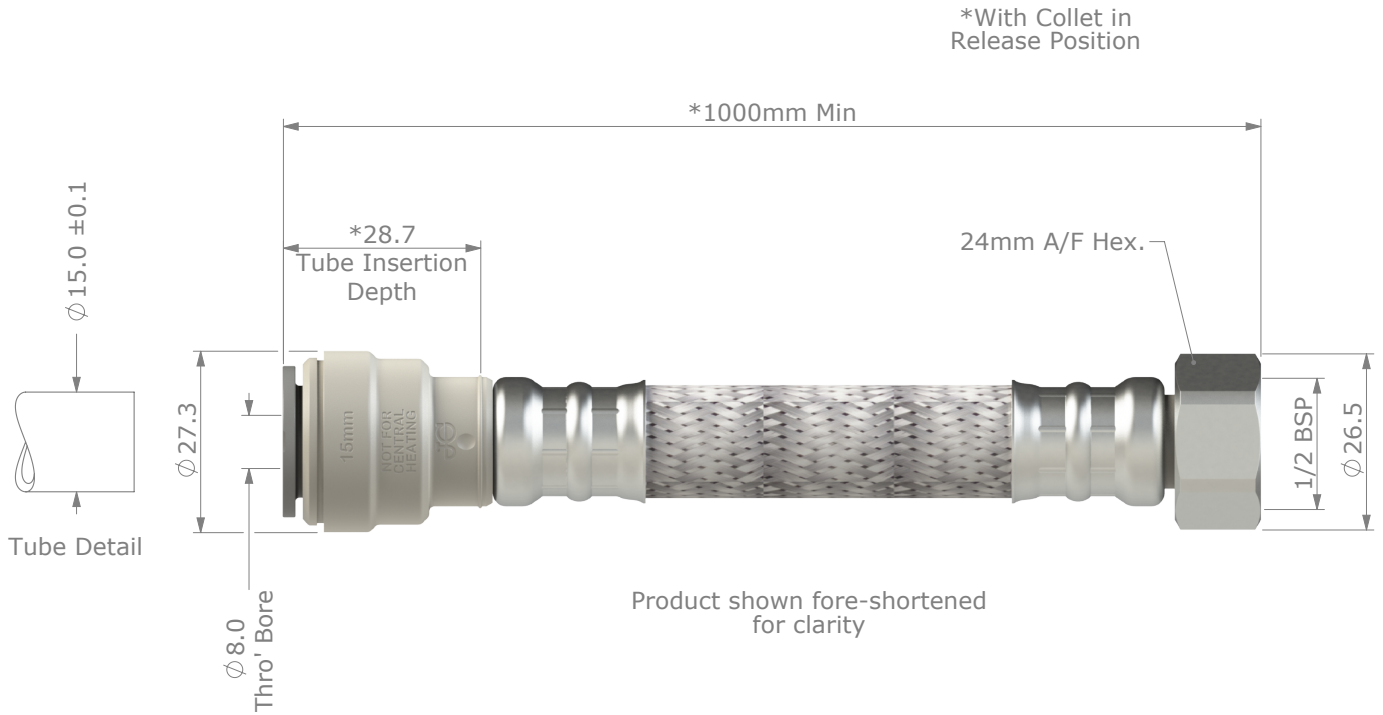

Dimensions in mm

Parts List			
Part Description	Material	Part Description	Material
15mm x 1/2 ID Hose Connector	See DS-NC448-02-X, Light and Dark Grey	1/2 BSP Sealing Washer	Ethylene Propylene (EPDM), Black
1/2 BSP Hose Barb	Acetal Copolymer (Unfilled), Light Grey	Ferrule, 17mm	Stainless Steel
1/2 BSP Captive Nut	Brass, Nickel Plated	13mm ID Flexible Braiced Hose	Ethylene Propylene / Stainless Steel

Technical Information	
Working Pressures & Temperatures	Applications
6 bar at 65°C    12 bar at 20°C	Hot and Cold Water    ✓ Central Heating        ✗

The Copyright in this drawing and the products referred thereon belong to John Guest International Limited and this drawing nor the information contained herein shall be produced in any form or used for any purpose without written consent © 2019

The company has a policy of continuous research and development and reserves the right to amend without notice the specification and design of all products illustrated. For details of Terms and Conditions and any other technical enquiries, please contact our Customer Services Department on 01895 449233. Alternatively, call our Technical Helpdesk on 01895 423333